

**Post Frame
and
Residential
Installation
Guide**



Ultra 2000

.....

Includes:

- Ultra 2000 Panel Installation Guide
- Stock Trim Profiles
- Ultra 2000 Trim Installation Guide

Important Notice

The application and detail drawings in this manual are strictly for illustration purposes and may not be applicable to all building designs or product installations. All projects should conform to applicable building codes for that particular area. It is recommended to follow all building codes and standard industry practices.

Jensen Bridge & Supply Company is not responsible for the performance of the roof system if it is not installed in accordance with the suggested instructions referenced in this installation manual or in the product overview. If there is a conflict between this manual and the actual erection drawings, the erection drawings are to take precedence.

Prior to ordering and installing materials, all dimensions should be verified by field measurements.

Jensen Bridge reserves the right to modify, without notice, any details, recommendations or suggestions. Any questions you may have regarding proper installation of the roofing system should be directed to your Jensen Bridge representative.

Consult Jensen Bridge for any additional information not outlined in this manual.

This manual is designed to be utilized as a guide when installing Residential roofing systems. It is the responsibility of the erector to ensure the safe installation of this product system.

Table of Contents

Ultra 2000 Profile, Colors Available, Additional Accessories	4, 5
Ultra 2000 Post Frame Panel Installation Guide.....	6, 7
Ultra 2000 Post Frame Trim Installation Guide:	
One Piece Soffit, Fascia Eave Trim, Gable Trim.....	8
Sidewall Flashing, Ridge Cap, W Valley	9
End Wall Flashing, Outside Corner, Inside Corner, Overhead Door Trim	10
Drip Cap, Shingle Style Drip Edge, Door Opening Trim, Rat Guard.....	11
Zee Trim, J Channel, Box Base Trim, F & J Trim	12
Fascia, Round & Square Track Cover	13
Ultra 2000 Residential Panel Installation Guide	14, 15
Ultra 2000 Residential Trim Installation Guide:	
Shingle Style Drip Edge, Flat Eave Trim	16
C Style Drip, Rake Trim, W Valley	17
End Wall, Gambrel, Pitch Change and Sidewall Flashings	18
Preformed Hip, Hip Cap, Ridge Cap, Half Ridge/Peak Trim.....	19
Reglet Trim, Chimney Flashing	20
Skylight Flashing	21
Vent Pipe Roof Boot	22
Why Install Steel Roof?.....	23

Panel Profile, Colors and Substrates Available

38" wide providing 36" coverage with ribs 9" on center

Available in lengths 1 ft. through 50* ft.

*for lengths over 50' contact your Jensen Bridge representative

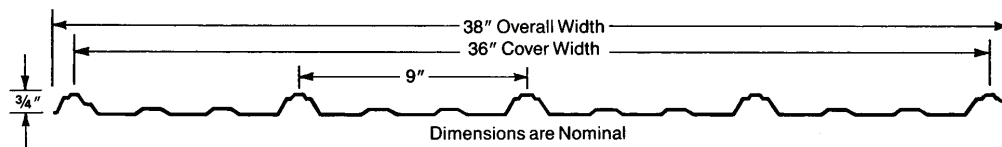

Standard G-60 and AZ50 29GA Stock Colors Available

Sandstone	Beige	Light Gray ²
Red ¹	Brown	Dark Gray
Patriot Red	Burnished Slate	Light Blue
Clay	Black	Ocean Blue
Regal White ^{1 2}	Burgundy	Silver
White ²	Evergreen ²	Tan

Also available in Acrylic Coated Galvanized or Galvalume and
Liner Grade in Regal White or Bright White

All of the above colors are available in 29GA G-60 and AZ50 Ultra 2000

¹ Available in G-100 Galvanized Coating

² Available in 26GA Ultra 2000

Accessories Available

In addition to our full line of standard and custom profile trims, we offer many accessories to complete your roofing and siding project. Our stock accessories include, but are not limited to, the following:

LP Vented Closures	Topside Formed Closure Strips
Profile Vent Material	Bottomside Formed Closure Strips
Gray Sealer Tape - 3/8" or 1" x 45' Lg. Roll	Square Sliding Door Track &
Expanding Closure Tape	Accessories Round Sliding Door Track &
Polycarbonate Light Panels—White or Clear	Accessories Cannonball Kwik-Frame
Peaklite Ridge Cap—White or Clear	Door Framing Cannonball Steel Walk
Synthetic Underlayment	Doors
Steel Solid or Perforated Soffit Panels	Cupolas
Woodgrip or Self-Drill Screws with Washer	Snow Fence
Pop Rivets	Snojax
Touchup Paint	Roof Boots

Paint Specifications

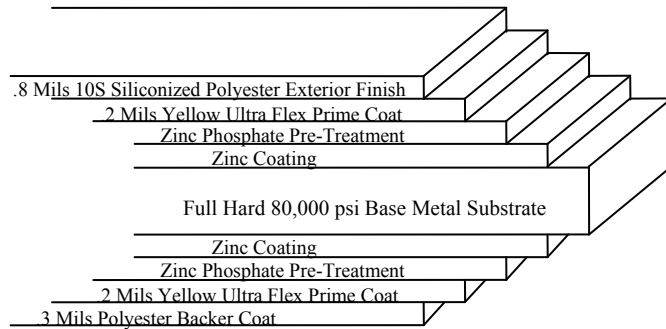

Paint Detail

Ultra 2000 features AkzoNobel Ceram-A-Star 1050 Siliconized Polyester Paint System starting with a zinc phosphate pre-treatment followed by:

Top: .2 Mils Yellow Ultra Flex Primer
.8 Mils Siliconized Polyester

Bottom: .2 Mils Yellow Ultra Flex Primer
.3 Mils White Polyester Backer

Bare galvanized and galvalume products have an acrylic coating. This coating helps protect the metal during manufacturing and installation.

Substrate: Ultra 2000 utilizes either galvanized or galvalume coated steel for their excellent corrosion resistance in both bare and painted condition.

Load Tables

ALLOWABLE UNIFORM LOADS IN POUNDS PER SQUARE FOOT— 3 OR MORE SPANS														
Gauge	WIND LOAD (UPLIFT)							LIVE LOAD (GRAVITY)						
	2'	3'	4'	5'	6'	7'	8'	2'	3'	4'	5'	6'	7'	8'
29	177	63.3	27.9	14.7	8.7	5.6	3.8	106	48.2	25.8	13.7	8.2	5.2	3.6
26	224	82.4	36.2	19.0	11.2	7.1	4.8	139	63.2	33.7	17.8	10.6	6.8	4.6

Panel Type	Min. Thick. in	Design Thick. in	Weight (psf)	I _{gross} in ⁴ /ft	Flexure								Shear V _a kips/ft	Web Crippling	
					Top in Compression				Bottom in Compression					End R _a kips/ft	Interior R _a kips/ft
					I _{xe} in ⁴ /ft	F _b ksi	S _{xe} in ³ /ft	M _a kip-in/ft	I _{xe} in ⁴ /ft	F _b ksi	S _{xe} in ³ /ft	M _a kip-in/ft			
29 Gauge	0.0150	0.0158	0.700	0.0105	0.0105	36.0	0.0188	0.677	0.0057	36.0	0.0147	0.529	0.481	0.133	0.308
26 Gauge	0.0190	0.0200	0.883	0.0133	0.0133	36.0	0.0237	0.853	0.0080	36.0	0.0193	0.695	0.608	0.193	0.490

- Values for 3 or more equal spans.
- Above loads are limited by stress and maximum deflection ratio of L/150 of span.
- Section properties of panels and allowable loads are calculated in accordance with the 1996 edition of "Specification for the Design of Cold-Formed Steel Structural Members".
- Minimum bearing length of 1.5 in. required.
- Allowable wind (uplift) loads have been increased by 4/3.
- Weight of panels has not been deducted from allowable loads.
- Connection strength is not considered in Uniform Load table. Adequate connections must be provided.



Class A Fire Rating
Class 4 Impact Rating
For Roofing System as to
External Fire Exposure
3VK7

Post Frame Installation Guidelines

Handling

When unloading bundles of Ultra 2000 extreme care should be used. Forklifts can dent or puncture bottom of sheets. Bundles may also bend or stretch in the

middle if they are too long for forklift unloading. The panel edges must be protected during unloading and handling to assure good fitting laps.

Cutting

Any cutting and trimming necessary should be done with a steel cutting blade, Carborundum blade, profile shear, or nibbler. **Always cut panels with the exterior side down.** Avoid any

sparks or hot particles to the panel finish which could cause pitting and red rust. Sheets can have sharp edges, always wear eye and hand protection.

Storage

Store Ultra 2000 panels in a dry place. Fan panels out to let air circulate. Stack off the ground on an incline to allow for any moisture run off. Panels should never be stored outside for more than a short period of time and should never be covered with plastic which allows condensa-

tion to occur. Any moisture trapped between sheets can cause superficial staining or lifting of the finish, considerably reducing the life of the paint. Failure to comply with the above recommendations voids any warranties.

Installation

Roof: Begin laying the roofing panels on the end of the building away from the prevailing wind so the side lap seams shall face away from the prevailing wind-driven rain. The first panel determines the alignment of all remaining panels on the roof, so **extreme care should be taken** to accurately square the first sheet. The over-lapping rib edge should be flush with the edge of the roof, and the panel should overhang the eave approximately three inches to provide for a drip edge. The side rib with the drain channel should face the direction in which the sheets are being laid down. When the panel is positioned, it should be fastened through the first rib, top and bottom. The panel should be attached completely before starting the next panel.

A tip for assuring straight alignment for successive rows of panels is to stretch chalk lines between nails driven into the ridge and end of each edge rafter. These lines will serve as guidelines to align panels.

If roof requires more than one horizontal row of panels, temporarily fasten at two points, not the ends, along main middle ribs of Panel #1 in lower corner. Next, install Panel #2 above and end lapping over Panel #1. Align both panels with chalk line. Install Panel #3 next to Panel #1, side lapping. Install Panel #4 above Panel #3 side lapping over Panel #2 and end lapping over Panel #3. Temporarily fasten all panels. Check alignment at ridge and eave. Permanently fasten when all panels are in line. Refer to Figure "1".

Ultra 2000 requires at least a 3/12 pitch. End laps are not recommended, but if an end lap is present a minimum of 12" should be used with butyl sealant tape. 1/2" Plywood or 5/8" thick OSB is recommended if a solid substrate is being used.

Sidewalls: Do not run siding all the way to the ground. Panels should lap at least 3" over splash board but not come in permanent contact with soil. The first siding panel must be plumb to assure straight alignment of the entire row of panels. Temporarily a wooden 1 x 2 or a steel rat guard can be used for a guideline about 3" below the top of the baseboard.

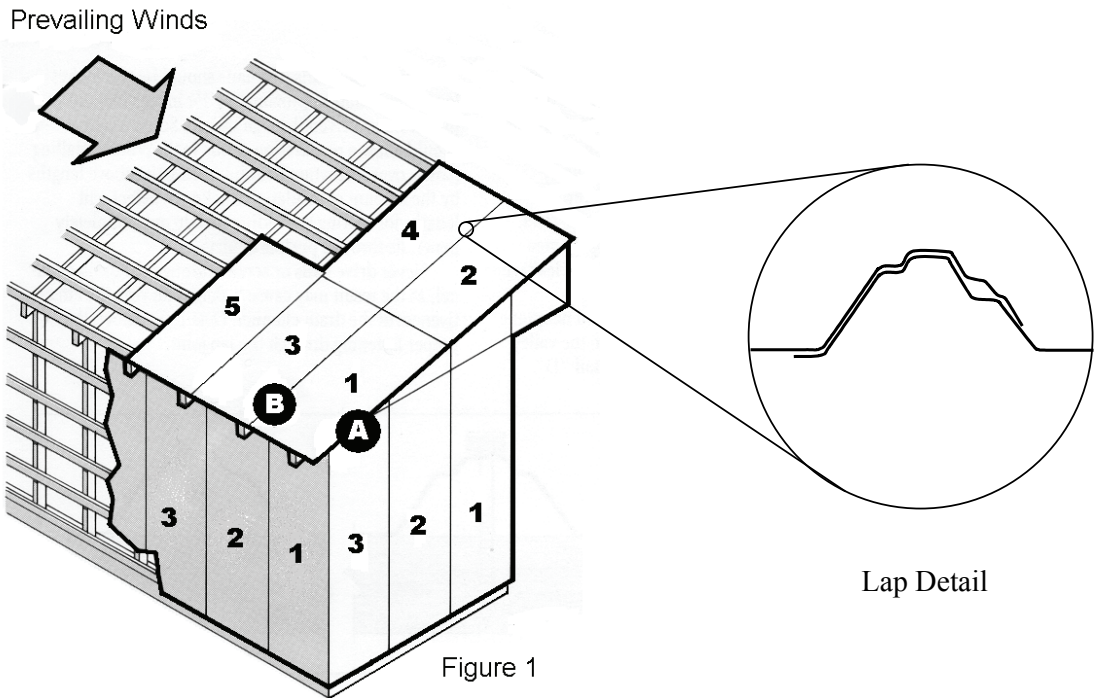

Figure 1

Fastening

Nails:

Roof—2” Galvanized ring shank nails with a neoprene gasket should be driven through the top of each major rib, as in Drawing #1, taking care not to over-drive. The washer should be compressed securely against the metal.

Sidewalls—1-1/2” nails should be driven through the flat next to each major rib as in Drawing #2.

Screws:

When using plated self-drilling wood screws with combination metal and neoprene washer, at least 1” penetration should be attained. Fasten in flat along each major rib on both roofing and siding as in Drawing #2 making sure the washer is secure.

NOTE: Stainless steel screws and a vapor barrier should be used when fastening to ACQ, CA, or ACZA treated wood products. Recommendations should be obtained from the treated lumber supplier.

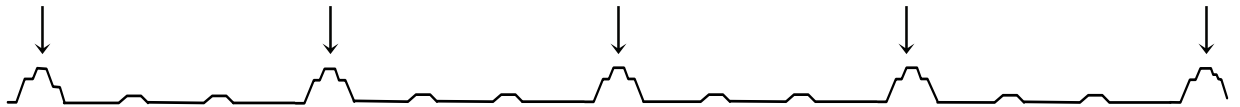

Drawing #1— Nail Fastener Positions



Drawing #2— Screw Fastener Positions for Intermediate Supports



Drawing #3— Screw Fastener Positions for Eaves, Ridge and End laps

CORRECT	TOO LOOSE	TOO TIGHT

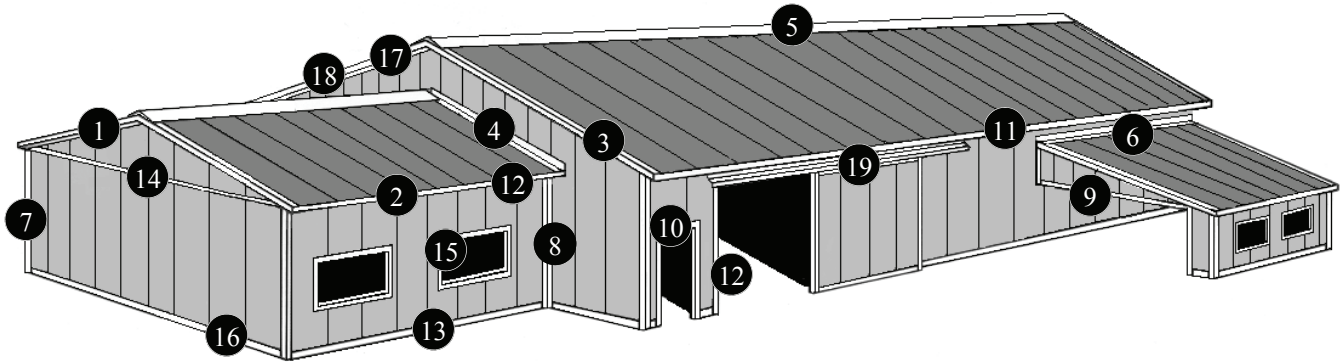

One Piece Soffit

Length: 10'4"

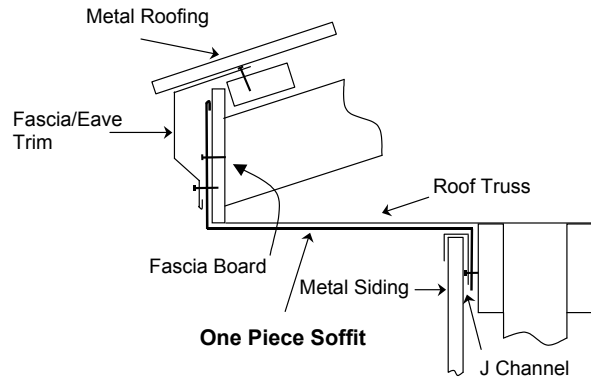
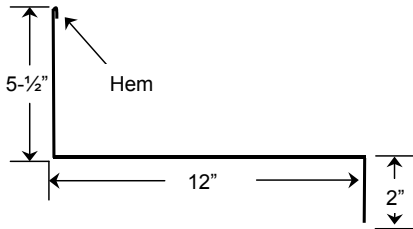

2 Fascia Eave Trim
Length: 10'4"

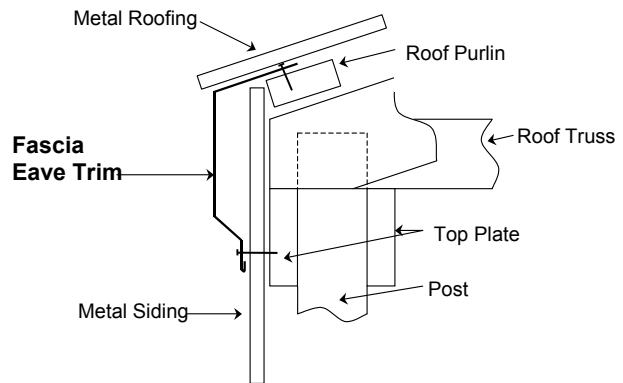
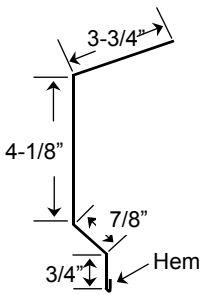

3 Gable Trim (Same as Outside Corner)
Length: 10'4", 12'4", 14'4", and 16'4"

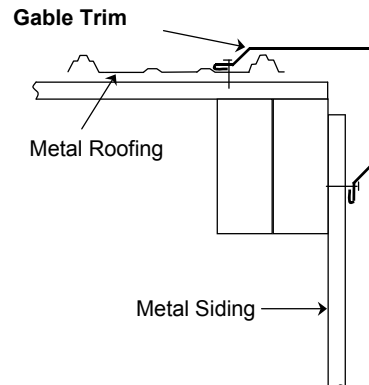
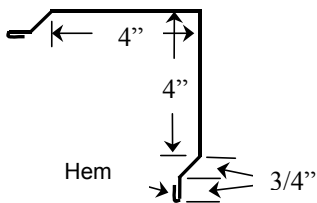

④ **Sidewall Flashing**
Length: 10'4"

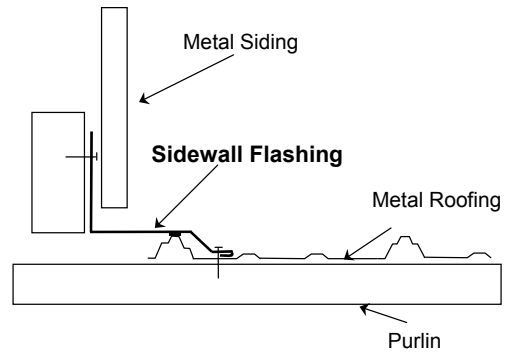
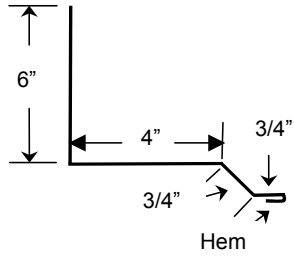

⑤ **Ridge Cap, 14" Wide**
Length: 10'4"

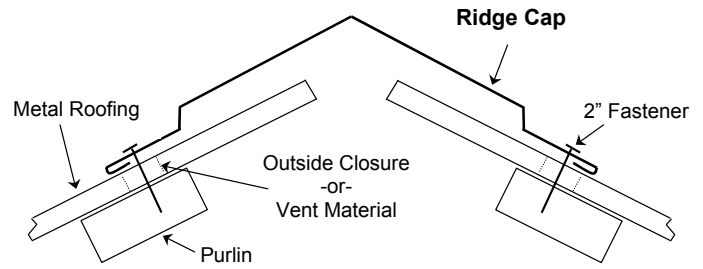
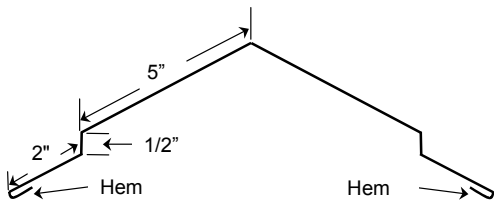

⑤ **Ridge Cap, 20" Wide**
Length: 10'4"

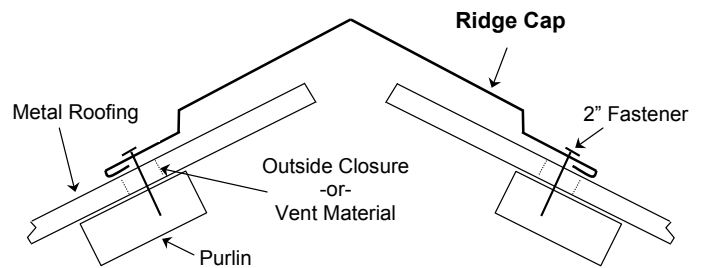
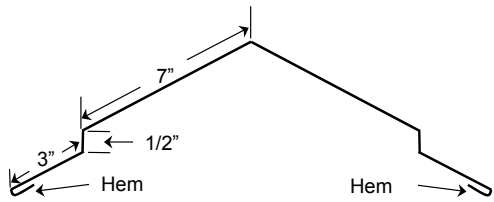

W Valley Trim
Length: 10'4"

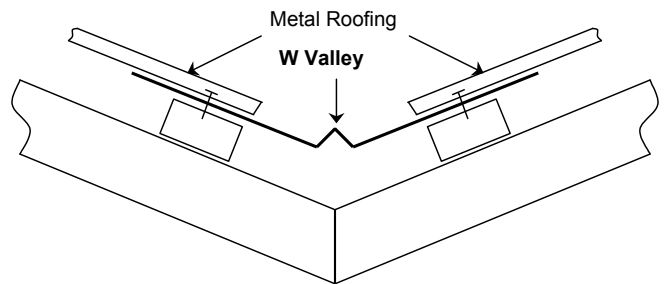
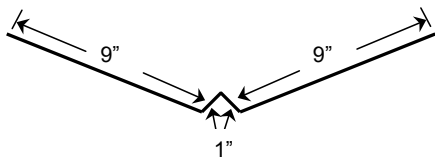

6 End Wall Flashing
Length: 10'4"

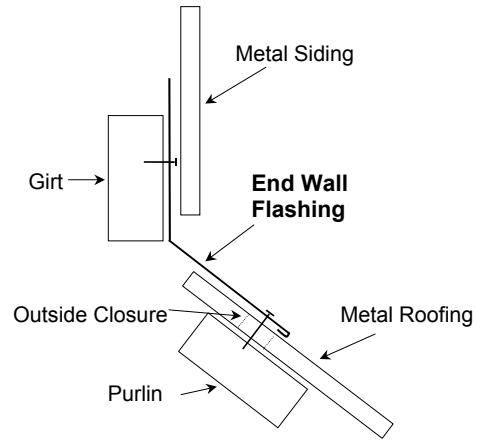
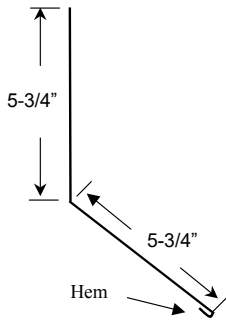

7 Outside Corner
Length: 10'4", 12'4", 14'4", and 16'4"

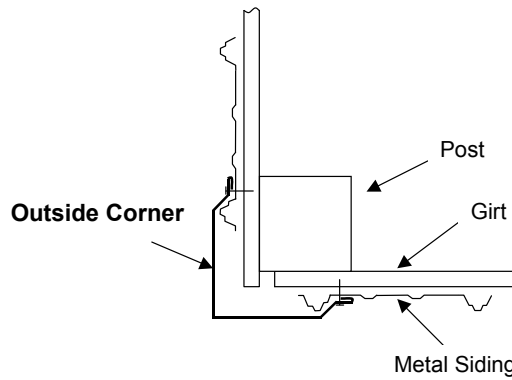
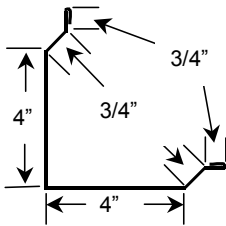

8 Inside Corner
Length: 10'4", 12'4", 14'4" and 16'4"

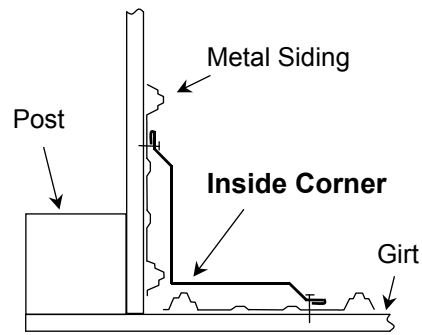
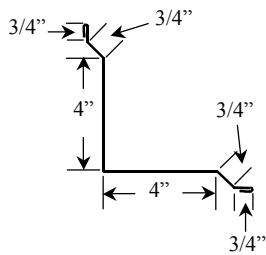

9 Overhead Door Trim
Length: 10'4" and 12'4"

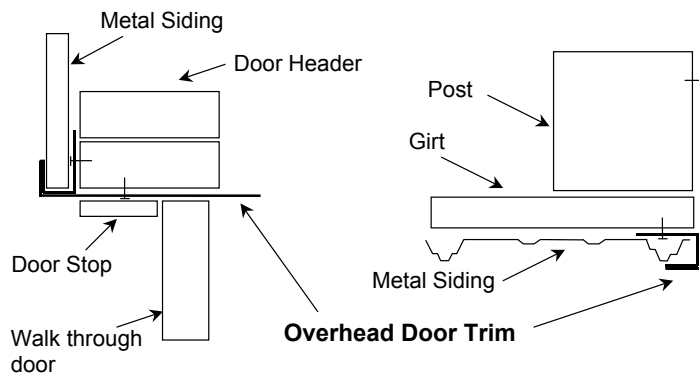
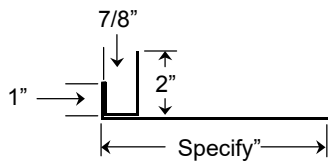

10 Drip Cap
Length: 10'

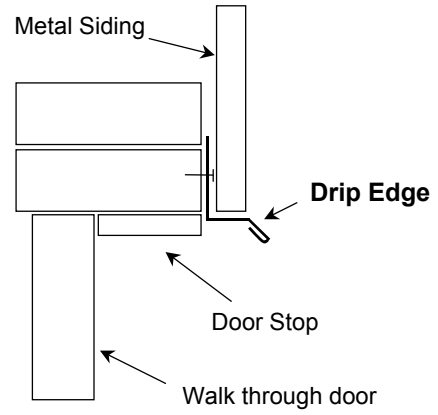
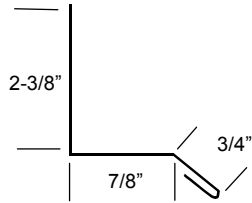

11 Shingle Style Drip Edge
Length: 10'4"

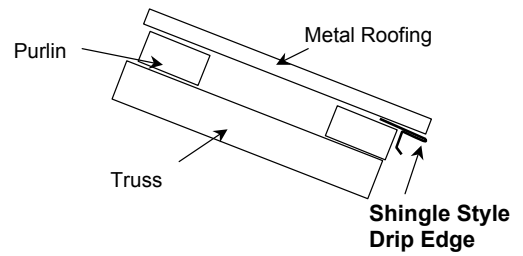
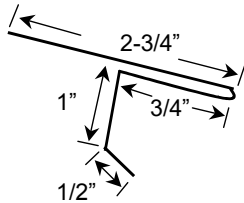

12 Door Opening Trim
Length: 10'4"

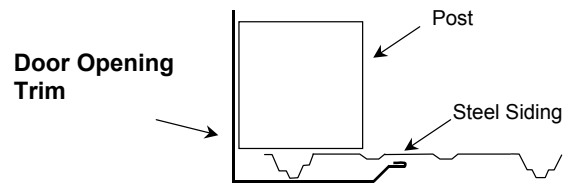
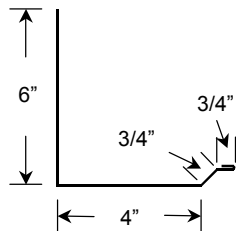

13 Rat Guard
Length: 10'

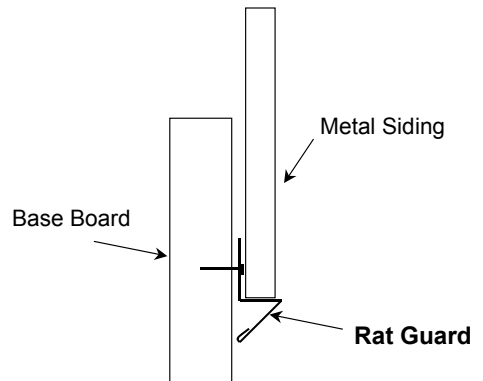
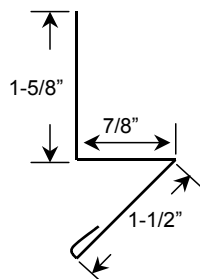

14 **Zee Trim**
Length: 10'

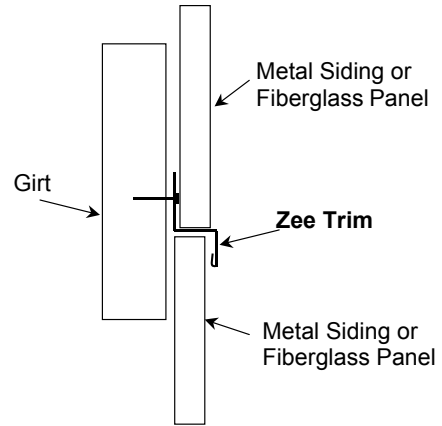
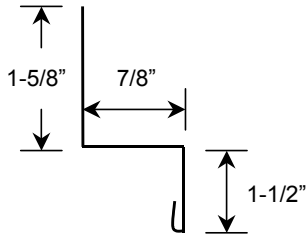

15 **J Channel**
Length: 10'

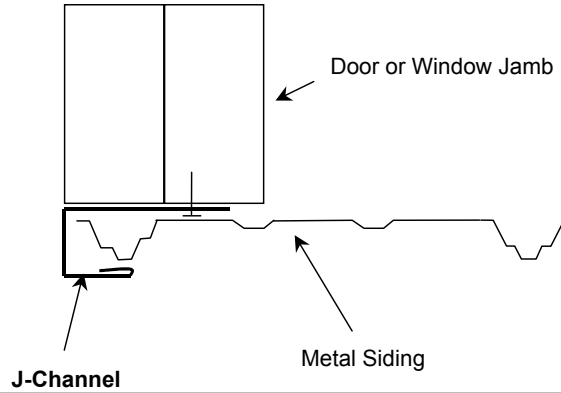
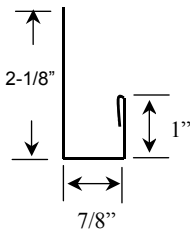

16 **1 & 1-1/2" Box Base Trim**
Length: 10'4"

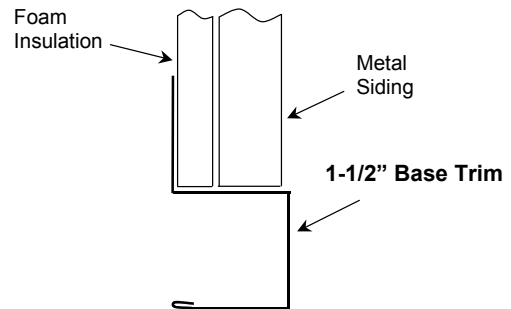
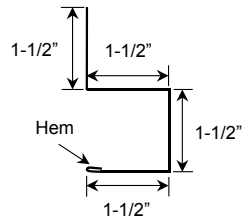
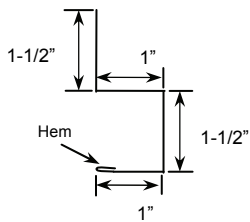

17 **F & J Trim**
Length: 10'4"

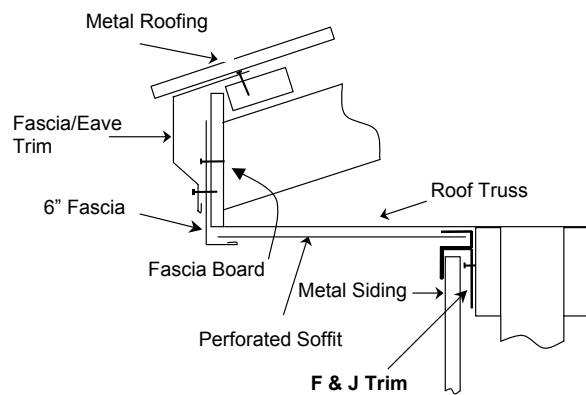
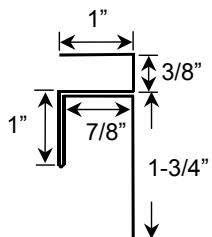

18 4", 6", or 8" Ribbed Fascia
Length: 10'4"

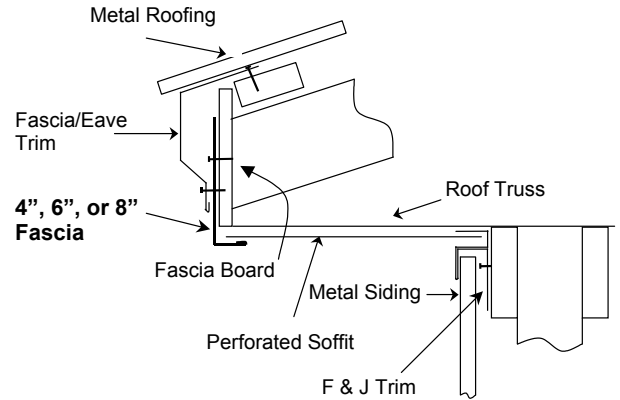
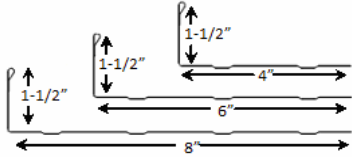

19 Square Track Cover
Length: 10'4"

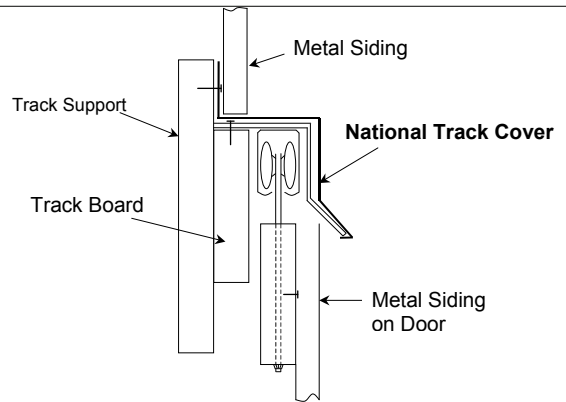
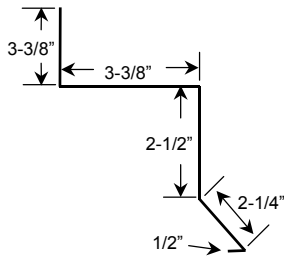

19 Round Track Cover
Length: 10'4"

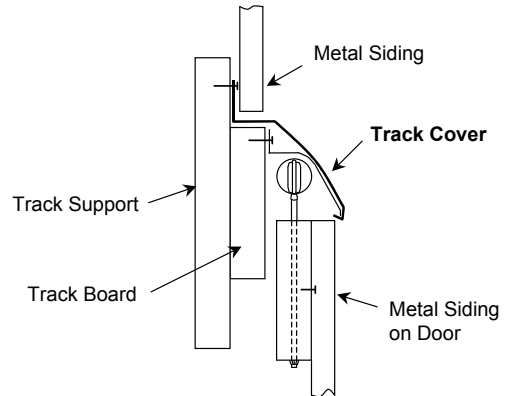
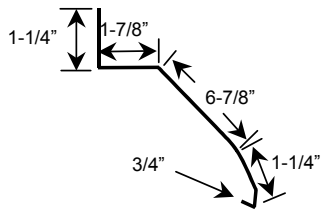

19 Round Double Track Cover
Length: 10'4"

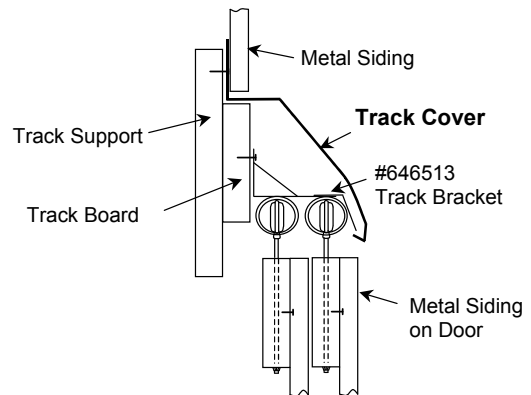
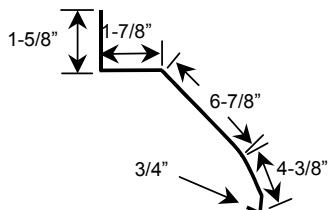

Residential Installation Guidelines

Handling

When unloading bundles of Ultra 2000 extreme care should be used. Forklifts can dent or puncture bottom of sheets. Bundles may also bend or stretch in the

middle if they are too long for forklift unloading. The panel edges must be protected during unloading and handling to assure good fitting laps.

Cutting

Any cutting and trimming necessary should be done with a steel cutting blade, Carborundum blade, profile shear, or nibbler. **Always cut panels with the exterior side down.** Avoid any

sparks or hot particles to the panel finish which could cause pitting and red rust. Sheets can have sharp edges, always wear eye and hand protection.

Storage

Store Ultra 2000 panels in a dry place. Fan panels out to let air circulate. Stack off the ground on an incline to allow for any moisture run off. Panels should never be stored outside for more than a short period of time and should never be covered with plastic which allows condensa-

tion to occur. Any moisture trapped between sheets can cause superficial staining or lifting of the finish, considerably reducing the life of the paint. Failure to comply with the above recommendations voids any warranties.

Roof Preparation

Sub-structures should be checked for uniformity and should be in good condition. 1/2" Plywood or 5/8" thick OSB is recommended. While Ultra 2000 can be installed over existing shingles, it is recommended that existing shingles be removed. Roof should

debris and nails. A minimum 3/12 slope is recommended. Substrate should be covered with a synthetic underlayment or 30# felt. Fold over gables and eave 1 to 2 inches. Ice and water shield should be used where required by code. End laps are not recommended, but if an end lap is present a minimum of 12" should be used with butyl sealant tape.

Sealants

Silicone sealants are not recommended for painted panel applications. A good urethane caulk is preferred. Tape sealant

should be used at any joints to assure weather tightness.

Installation

Before roofing panels can be installed, Valley Flashing, Drip Edge or Eave Trim and Pre-formed Hip Trim must be installed (see trim installation details for closure and sealant recommendations). Once these trims have been installed, begin laying the roofing panels on the end of the building away from the prevailing wind so the side lap seams shall face away from the prevailing wind-driven rain. The first panel determines the alignment of all remaining panels on the roof, so **extreme care should be taken** to accurately square the first sheet. The overlapping rib edge should be flush with the edge of the roof, and the panel should

slightly overhang the drip edge trim. The side rib with the drain channel should face the direction in which the sheets are being laid down. When the panel is positioned, it should be fastened beside the first rib, top and bottom. The panel should be attached completely before starting the next panel.

A tip for assuring straight alignment for successive rows of panels is to stretch chalk lines between nails driven into the ridge and end of each edge rafter. These lines will serve as guidelines to align panels.

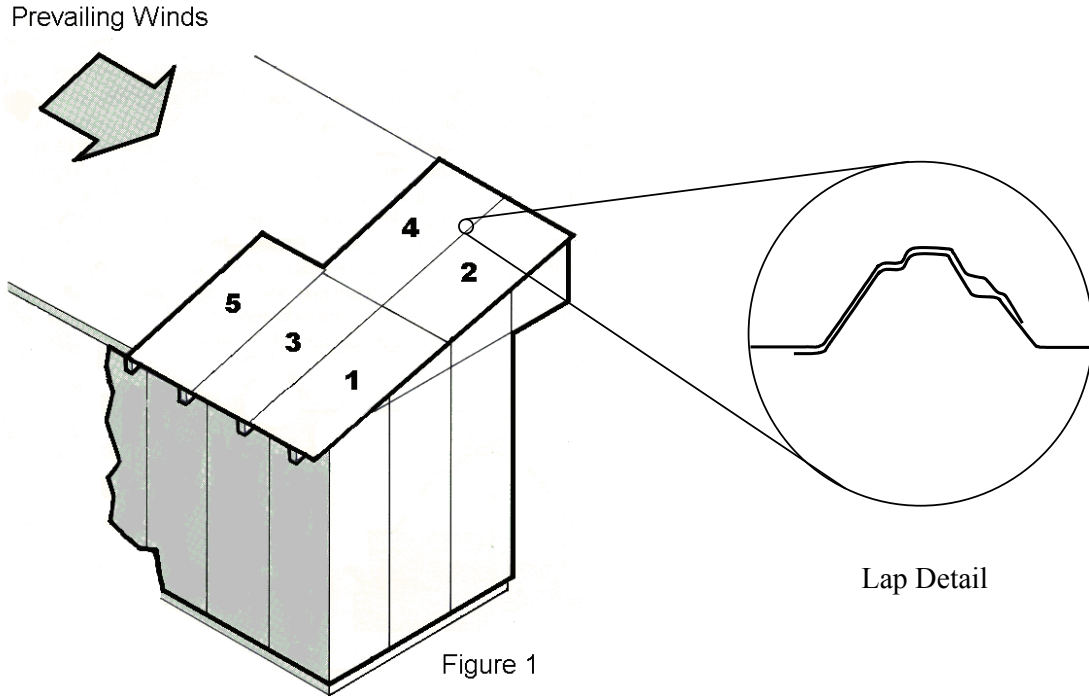

Figure 1

Installation
(continued)

If roof requires more than one horizontal row of panels, temporarily fasten at two points, not the ends, along main middle ribs of Panel #1 in lower corner. Next, install Panel #2 above and end lapping over Panel #1. Align both panels with chalk line. Install Panel #3 next to Panel #1, side lapping. Install Panel #4 above Panel #3 side lapping over Panel #2 and end lapping

over Panel #3. Temporarily fasten all panels. Check alignment at ridge and eave. Permanently fasten when all panels are in line. Refer to Figure "1".

When using more than one panel in a row, install with a minimum 8" end lap and butyl sealant tape.

Fastening

When using plated self-drilling wood screws with combination metal and neoprene washer, at least 1" penetration should be attained. Fasten in flat along each major rib as in Drawing #1 making sure the washer is secure in rows a maximum of 24" apart.

For eaves, ridge and end laps, fasten screws in flat along each side of each major rib as in Drawing #2. Again, making sure the washer is properly secured.

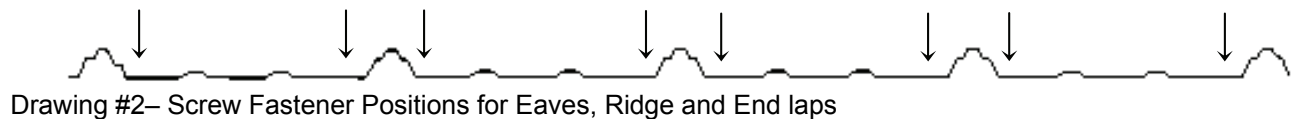

CORRECT	TOO LOOSE	TOO TIGHT

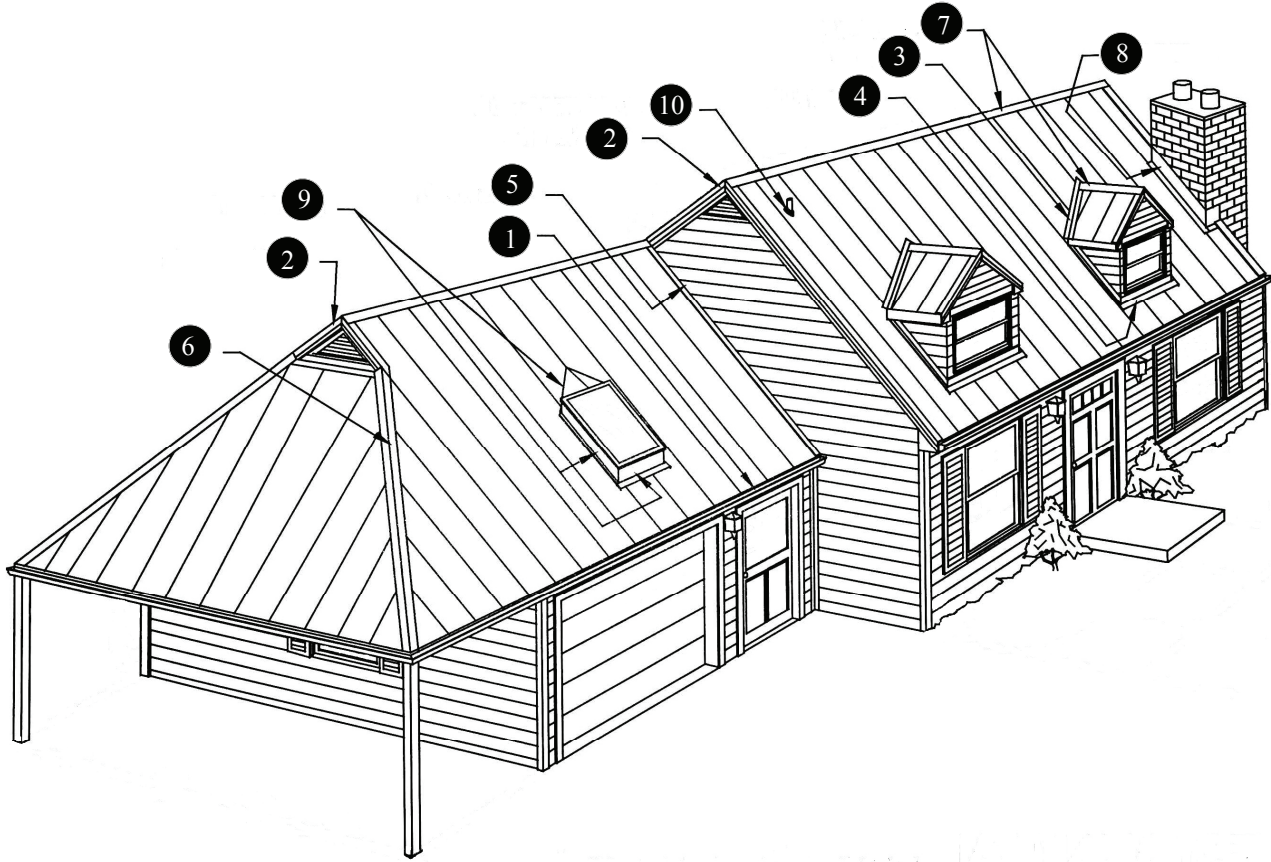

① **Shingle Style Drip Edge**
Length: 10'4"

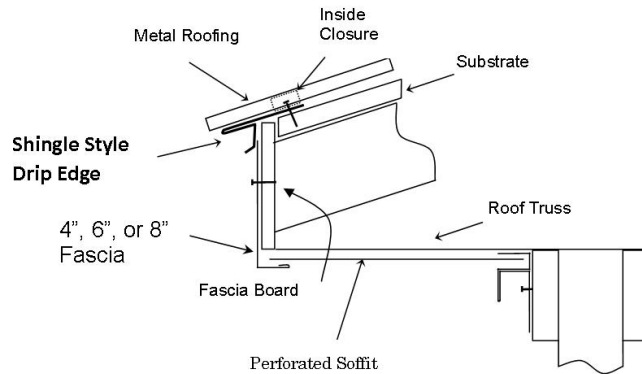
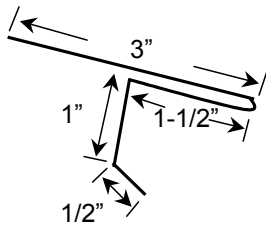

① **Flat Eave Trim**
Length: 10'4"

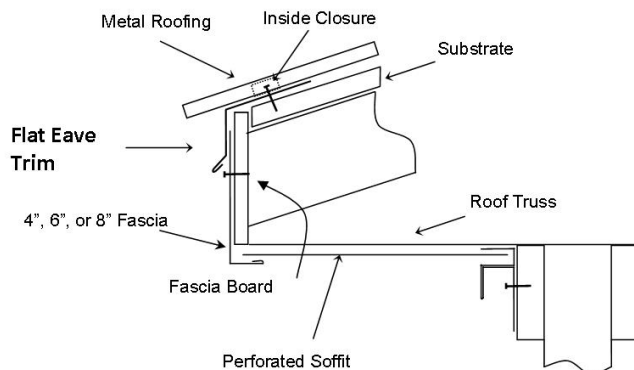
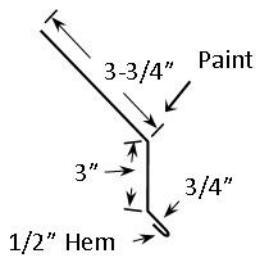

Note: Underlayment and substrate details have been omitted for clarity. Install roof substrate and moisture barriers according to local building codes.

① **C Style Drip (J Channel)**
Length: 10'4"

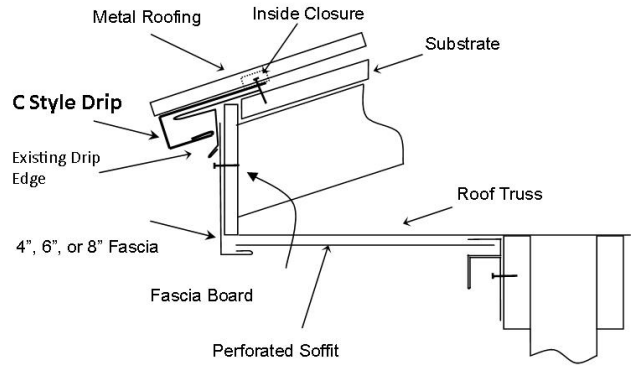
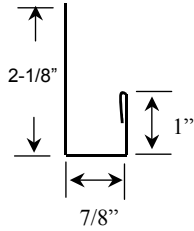

② **Residential Rake Trim—Type 1**
Length: 10'4"

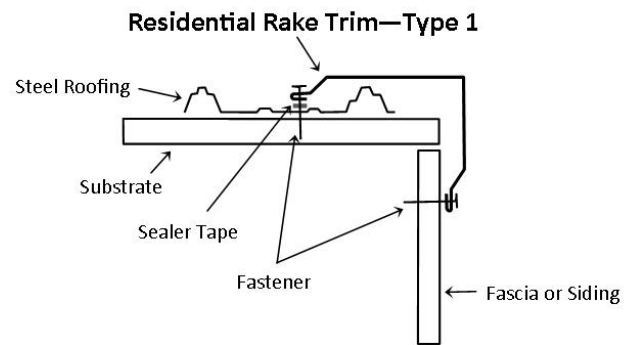
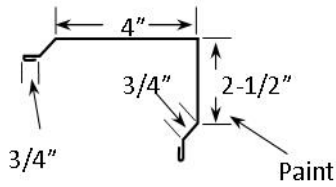

② **Residential Rake Trim—Type 2**
Length: 10'4"

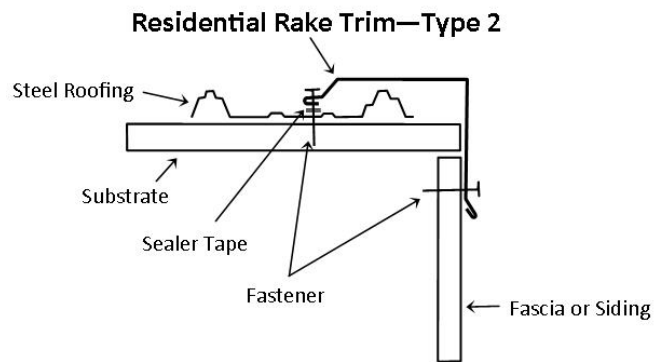
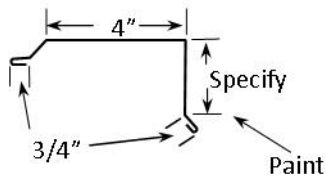

③ **W Valley Trim**
Length: 10'4"

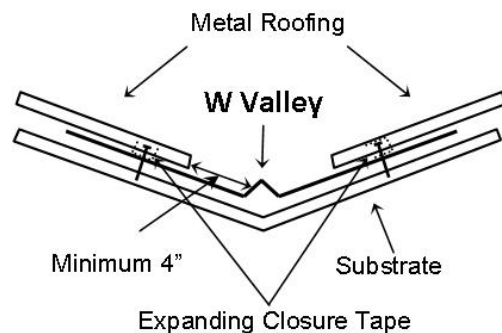
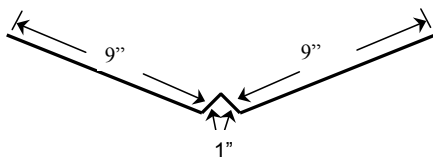

Note: Underlayment and substrate details have been omitted for clarity. Install roof substrate and moisture barriers according to local building codes.

4 End Wall Flashing
Length: 10'4"

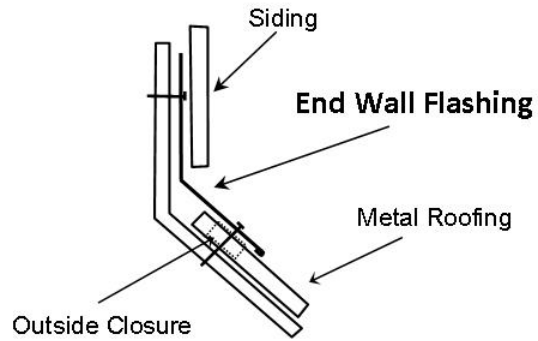
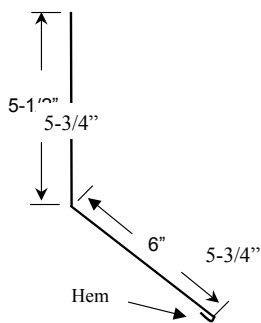

Gambrel Flashing
Length: 10'4"

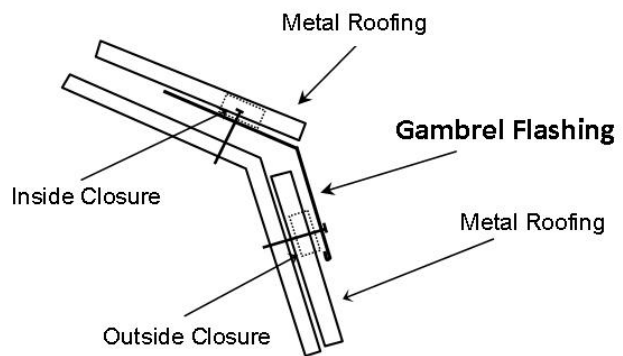
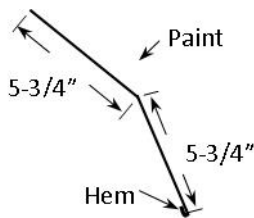

Pitch Change
Length: 10'4"

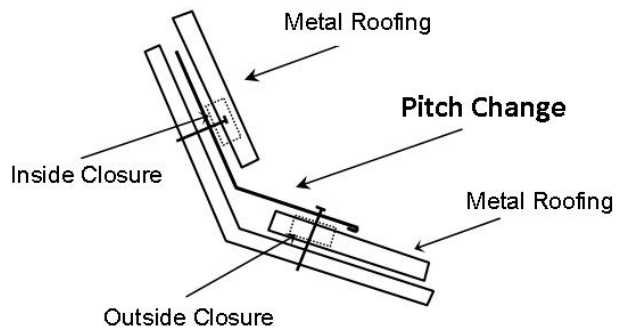
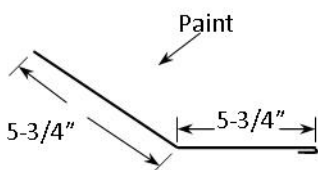

5 Side Wall Flashing
Length: 10'4"

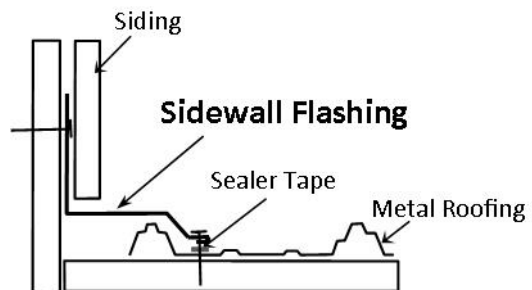
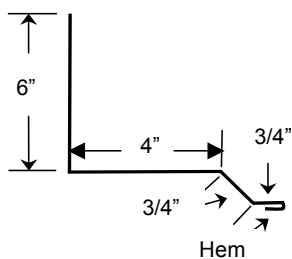

Note: Underlayment and substrate details have been omitted for clarity. Install roof substrate and moisture barriers according to local building codes.

⑥ **Preformed Hip**

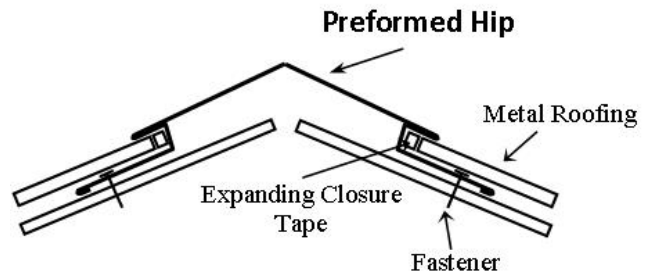
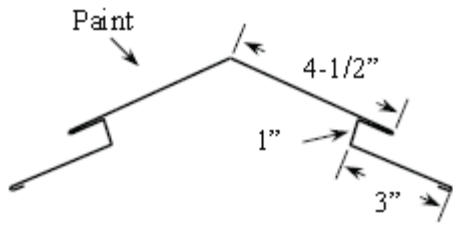

⑥ **Hip Cap**
Length: 10'4"

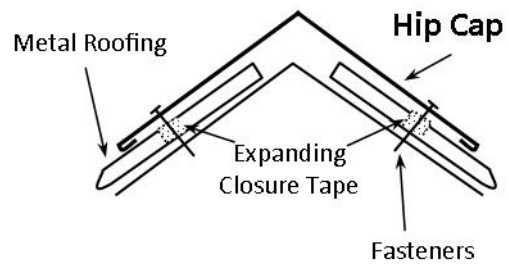
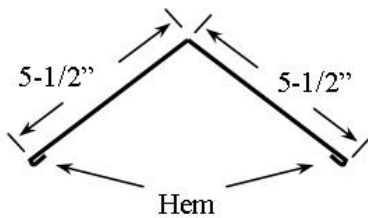

⑦ **Ridge Cap, 14" Wide**
Length: 10'4"

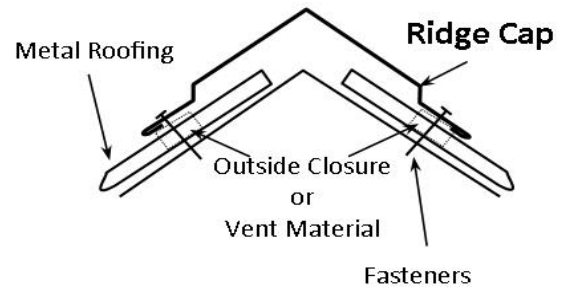
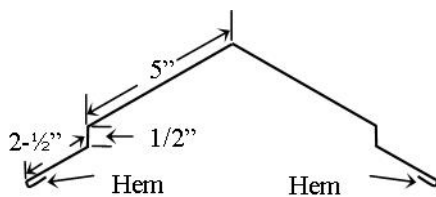

Half Ridge/Peak Trim
Length: 10'4"

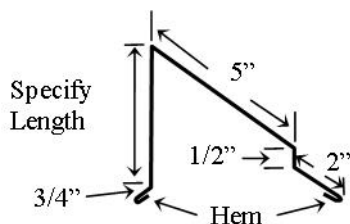

Half Ridge/Peak Cap

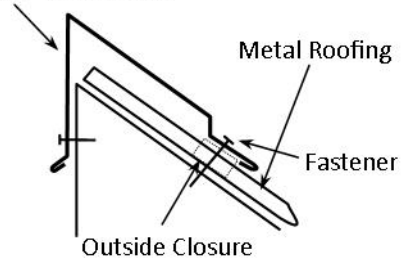

Note: Underlayment and substrate details have been omitted for clarity. Install roof substrate and moisture barriers according to local building codes.

Reglet Trim

Length: 10'

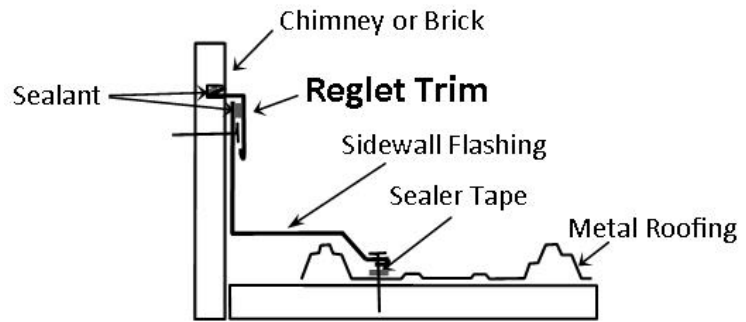
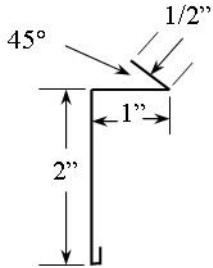

⑧ **Chimney Flashing—using Side Wall Flashing, End Wall Flashing, and Flat Trim Sheet**

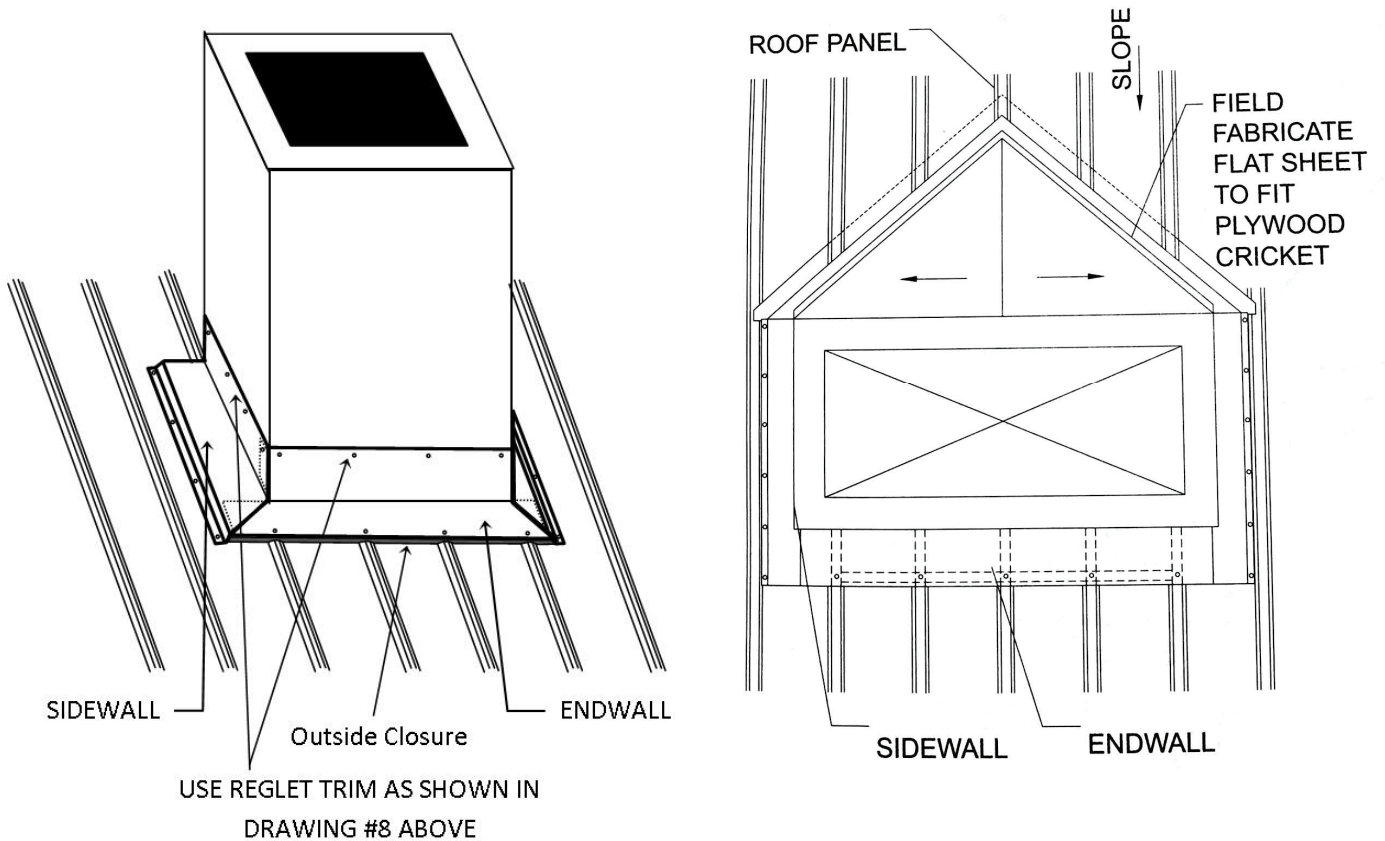

Note: Underlayment and substrate details have been omitted for clarity. Install roof substrate and moisture barriers according to local building codes.

9 Skylight or Alternate Chimney Flashing option

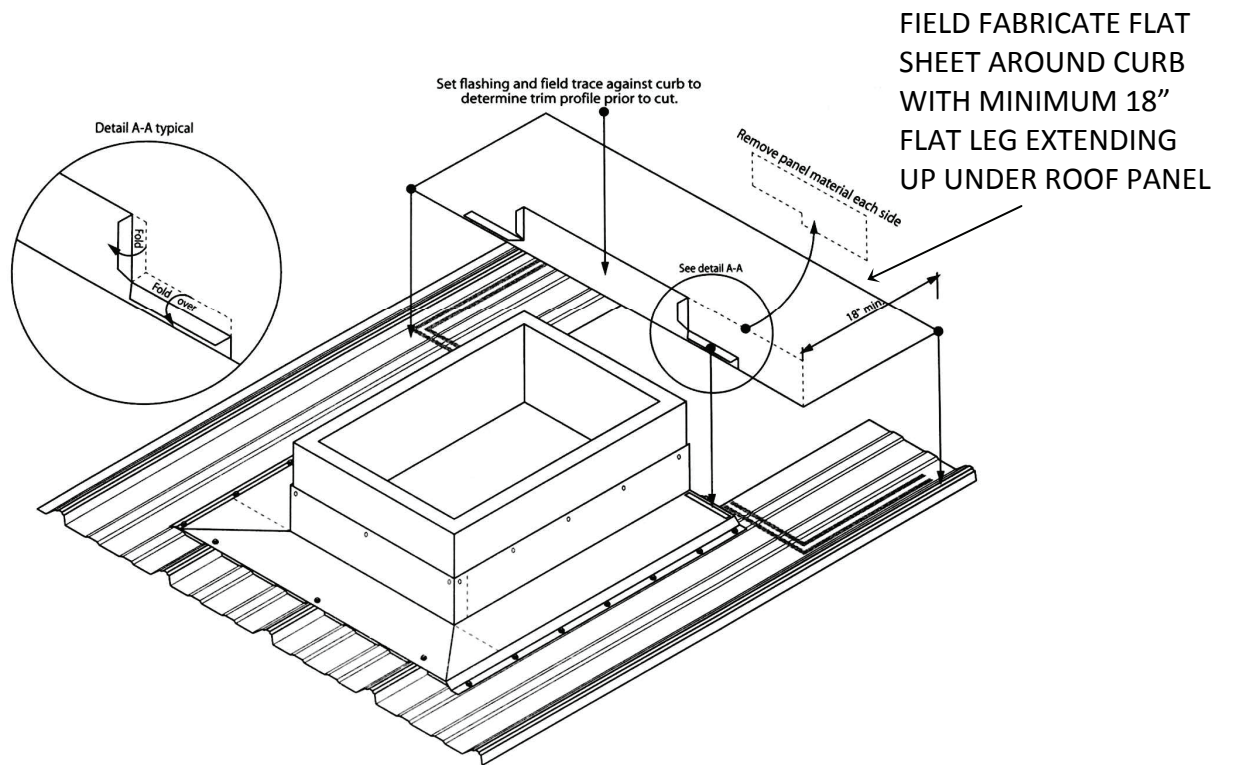
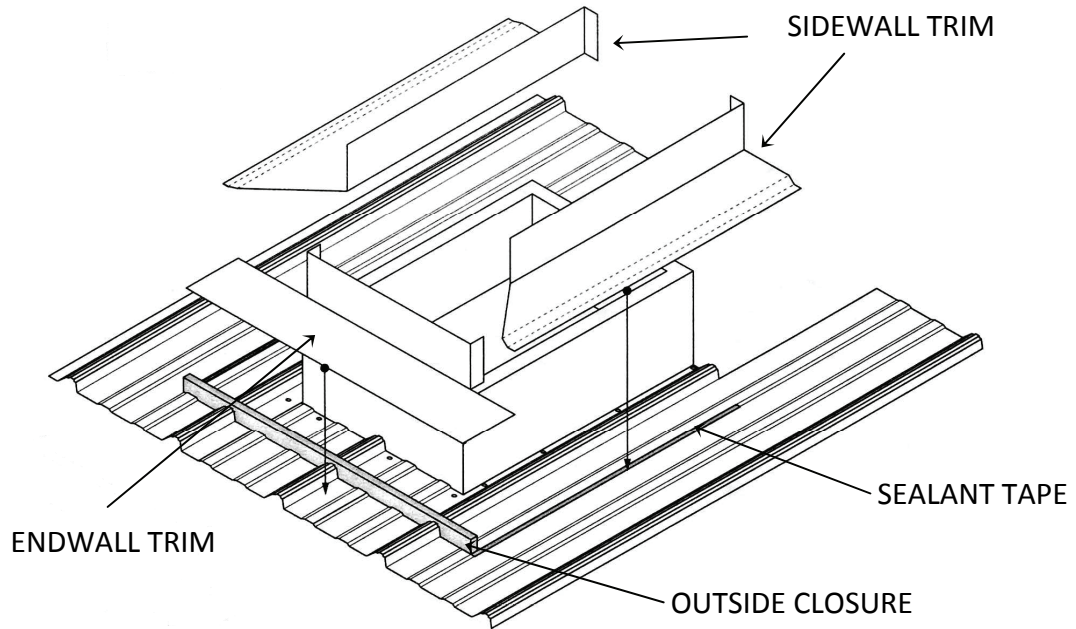

Note: Use skylight manufacturer's flashing kit if available. If not available, sealant and custom bent trim can be used to seal up top edge of above flashings.

⑩ VENT PIPE ROOF PENETRATION

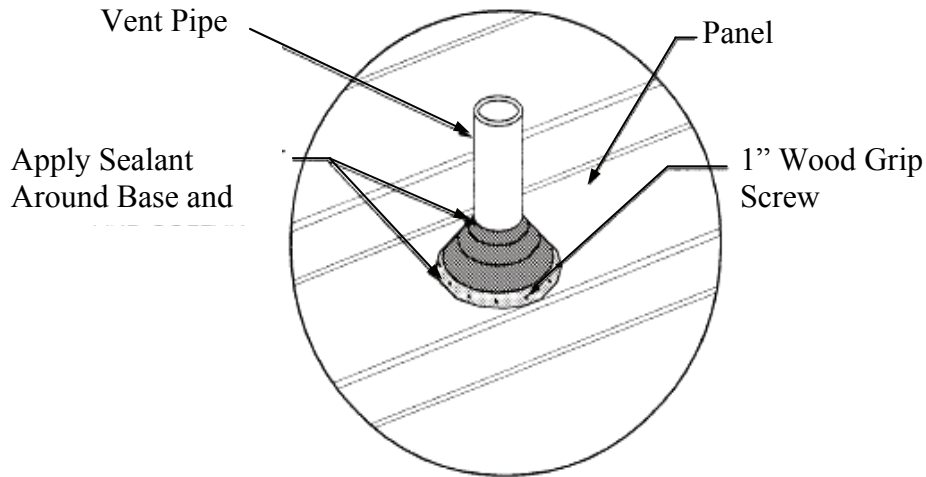

Rubber Roof Jack



Available Sizes:

#3 (1/4" to 4" O.D. Pipe)

#4 (3" to 6" O.D. Pipe)

#8 (7" to 13" O.D. Pipe)

CAUTION: THE FOLLOWING PROCEDURES ARE FOR VENT PIPES 6" OR LESS

AND NOT TRANSMITTING EXTREMELY HOT OR CAUSTIC MATE-

Notes:

- 1) Determine the size and length of the vent pipe to be raised.
 - 2) Take the appropriate measurements for the vent location and mark them on the panel. The vent pipe must extend through the flat of the roof panel. If the vent pipe extension cannot be raised directly into the flat of the new roof panel, elbows should be used to offset the pipe. Cut the panel to fit the vent pipe properly.
 - 3) Use a light gauge angle to secure and plumb the vent pipe to the framing system.
 - 4) Flash the vent pipe with a rubber roof jack or similar pipe flashing.
 - 5) Apply sealant between the panel and the base of the rubber roof jack as well
-

Why Install a Steel Roof?

Steel roofing has become the fastest growing product in the roofing industry. Exceptional manufacturing methods and new paint finishing technology allow it to meet the most demanding modern roofing standards.

Steel roofing is a wonderful finish to a new home or business. It also offers a practical and appearance enhancing replacement for an existing building.

Steel roofing is not only durable but also available in different configurations and colors, allowing it to adapt to multiple applications and typically requires less labor to install.

Steel roofing will out-perform conventional asphalt shingles under adverse weather conditions including high winds, hail, snow and rain.

Steel roofing eliminates the problems and costs associated with the removal and disposal of conventional asphalt roofing.

Steel roofing will not warp, rot, split or crack; is impervious to termites and pests and is virtually maintenance free.

Steel roofing is non-combustible for safe, superior fire resistance.

Steel roofing reflects and absorbs heat more efficiently than competing materials translating to lower cooling costs.

Although the initial cost of steel roofing may be higher than shingles, the cost/benefits ratio over the life of the roof is superior to that of a shingle system and far superior to either shake, slate or tiles.



BRIDGE & SUPPLY COMPANY

Main Office:

400 Stoney Creek Drive
PO Box 151
Sandusky, MI 48471

Ohio Plant:

9610 County Rd Fourteen
Wauseon, OH 43567

.....
Phone: (810) 648-3000
Fax: (810) 648-3549

.....
Phone: (419) 335-3200
Fax: (419) 335-3201